

STAGEPAS Series

PA Systems

STAGEPAS 250M



STAGEPAS 150M



Portable, expandable single speaker live sound systems.

- These systems include a passive speaker, detachable powered mixer, and speaker cable.
- Ideal as a compact main sound system or as a personal monitor system.
- An additional powered speaker can be added for broader coverage and bigger sound: MSR250 Powered Speaker for the STAGEPAS 250M, or MSR100 Powered Speaker for the STAGEPAS 150M.
- Both the 8-channel 150-watt STAGEPAS 150M mixer and the 10-channel 250-watt STAGEPAS 250M mixer can be used either while installed in the speaker compartment or detached for easy positioning and access.
- Built-in equalization and reverb add the finishing touches to your sound.
- STAGEPAS 250M features phantom power for condenser microphones and channel compression/limiting for added sonic control.
- XLR and phone-jack inputs on mono channels, and phone-jack and RCA pin-jack inputs on stereo channels allow connection to a wide range of sources.
- MIC/LINE switches select microphone or line level input matching for channels 1 through 4.
- The STAGEPAS speaker can be stand mounted using a standard speaker stand adaptor such as the ADP138, Ultimate BMB200, or equivalent.
- Auto Limiter prevents overload damage to power amplifier and speakers.
- LED output level meter.
- Optional BMS-10A Mic Stand Adaptor for the mixer unit.

OPTIONS (MSP5 STUDIO)

BMS10A Mic Stand Adaptor



The optional BMS-10A Mic Stand Adaptor makes it easy to mount the mixer on a microphone stand.

STAGEPAS 250M

OUTLINE

I/O	Mic inputs Phantom power	2 +15V DC (CH1-2)
Mixing capability	Mixing channels	2 mono + 4 stereo
Input channel functions		2-band PEQ, Digital reverb(CH1-2), Comp/Limiter(CH1-2; ON: Comp; OFF: Limiter)
Onboard processors		Music/Speech, Click assign function
Onboard amplifiers	Maximum output power @4ohms	250W

GENERAL SPECIFICATIONS

Total harmonic distortion		Less than 0.5%
Frequency response	Mixer section Speaker section	0, +1.0, -3.0dB; 20Hz-20kHz -10dB; 55Hz-20kHz
Hum & Noise	Equivalent input noise Residual output noise	Less than -106dBu (CH1/2) Less than -65dBu (SPEAKERS L/R)
Crosstalk		Less than 70dB
Speaker enclosure		2-way bass-reflex type, Polypropylene
Speaker components	LF HF	10" cone 1" compression driver
Maximum output level (1m; on axis)		116dB
Power requirements		AC100V, 120V, or 220-240V; 50/60Hz
Power consumption		35W
Dimensions (W x H x D)		342.0 x 544.5 x 298 mm (13" 1/2 x 21" 1/2 x 11" 3/4)
Net weight		13kg (28lbs 5/8) [Speaker x 2 + Powered Mixer]
Accessories		Owner's manual, AC code, 1x Speaker cable

DIMENSIONS

unit : mm

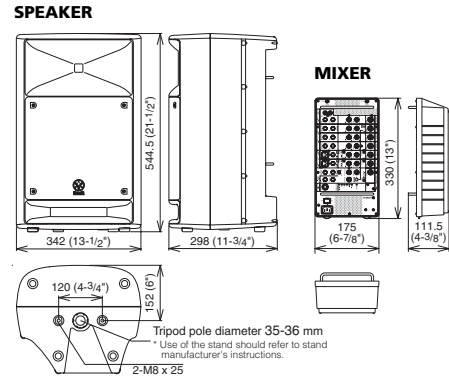

STAGEPAS 150M

OUTLINE

Mic inputs		2
Mixing channels		2 mono + 3 stereo
Input channel functions		2-band PEQ, Digital reverb(CH1-2)
Onboard processors		Music/Speech, Click assign function
Onboard amplifiers	Maximum output power @6ohms	150W

GENERAL SPECIFICATIONS

Total harmonic distortion		Less than 0.5%
Frequency response	Mixer section Speaker section	0, +1.0, -3.0dB; 20Hz-20kHz -10dB; 55Hz-20kHz
Hum & Noise	Equivalent input noise Residual output noise	Less than -106dBu (CH1/2) Less than -65dBu (SPEAKERS L/R)
Crosstalk		Less than 70dB
Speaker enclosure		2-way bass-reflex type, Polypropylene
Speaker components	LF HF	8" cone 1" compression driver
Maximum output level (1m; on axis)		112dB
Power requirements		AC100V, 120V, or 220-240V; 50/60Hz
Power consumption		15W
Dimensions (W x H x D)		275.0 x 455.5 x 255.0 mm (10" 7/8 x 17" 7/8 x 10" 1/8)
Net weight		9.6kg (21lbs 1/8) [Speaker x 2 + Powered Mixer]
Accessories		Owner's manual, AC code, 1x Speaker cable

DIMENSIONS

unit : mm

